





# Board Game Beaver

## SLEEPING GODS + ToR + Dungeons expansions Compatible Game Organiser



Eco friendly



Removable trays



Can store vertically



Flush lid



100 microns Supports Sleeves\*



29x28x10cm Fits Box size

### Components and stacking sequence

**1**

3x3 Character save trays

Dungeons expansion token tray

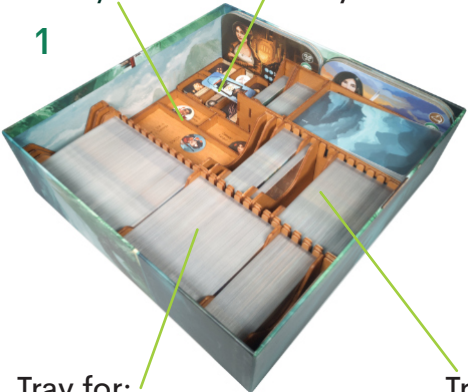

Tray for:

- Port Board
- Market cards
- Adventure cards
- Quest cards
- Completed quest cards
- Current quest cards

**2**

Various token tray

Tray for:

- Ability cards
- Discarded ability cards
- Level cards

Enemy card tray

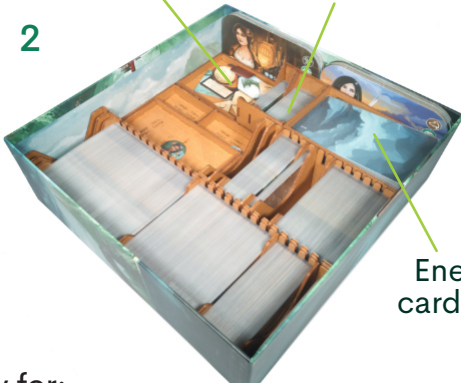

Tray for:

- Event cards
- Discarded event cards
- Camp cards (Dungeons)
- Arcade cards (Tides of Ruin)
- Current adventure cards (used and unused)

**3**

Ship save tray

Search & fatigue token tray

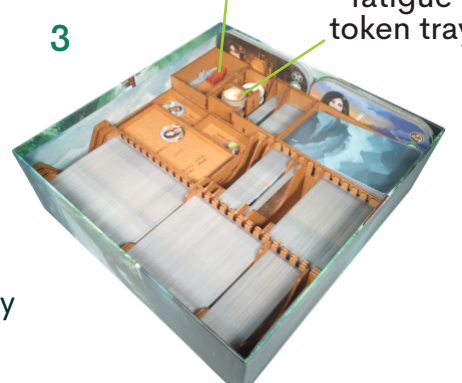

**4**

Resource & combat token tray

Status token tray

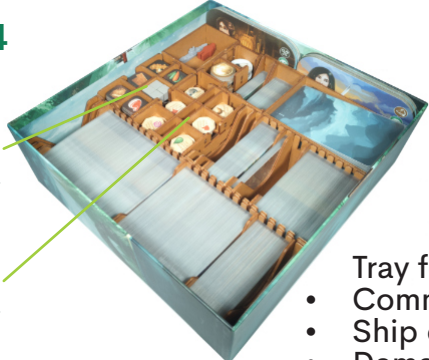

**5**

Tray for:

- Command tokens
- Ship damage tokens
- Damage tokens
- Coins



**6**



\*Maximum sleeve sizes: 62x94mm (standard European cards)  
46x71mm (mini European cards), 73x122mm (enemy cards)

# Assembly tips and general notes

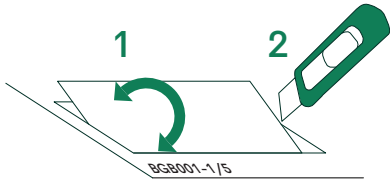

Gently remove parts from the sheet. Punching them out can split the wood. If a part resists, score the tabs with a hobby knife.

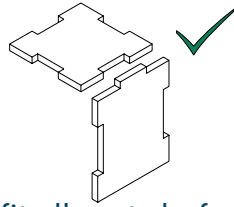

Dry-fit all parts before gluing to confirm orientation and sequence.

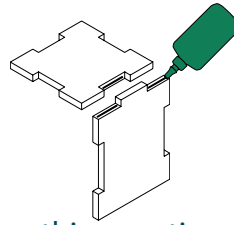

Apply a thin, continuous film of wood/PVA glue to one mating edge only. Glue isn't required for every joint, but it improves durability. Wipe any glue squeeze-out immediately with a clean cloth or paper towel.

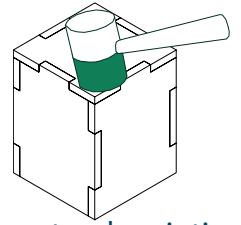

Due to natural variation in the wood, light taps with a rubber mallet may help seat tight joints.

(X) = Tray

# = Part of tray

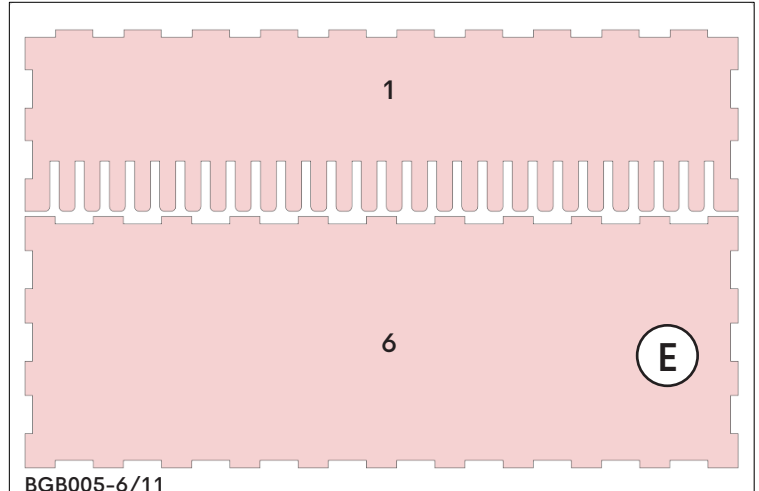
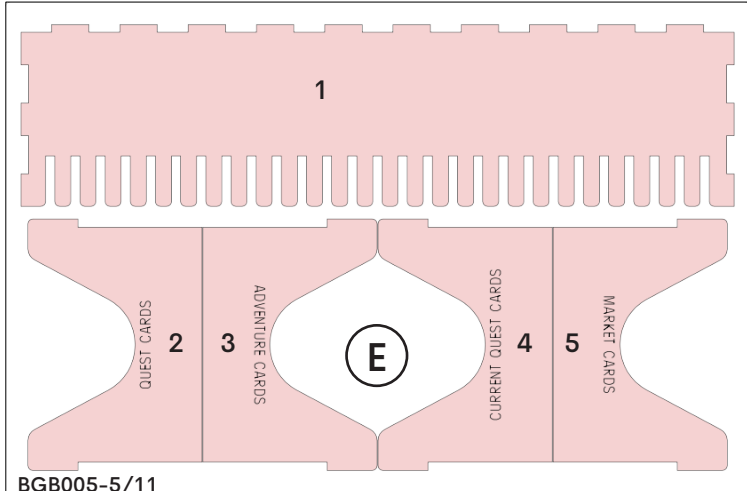
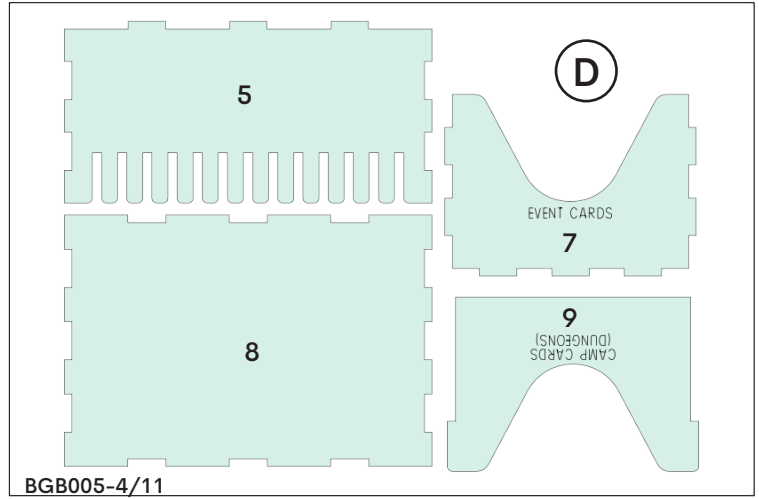
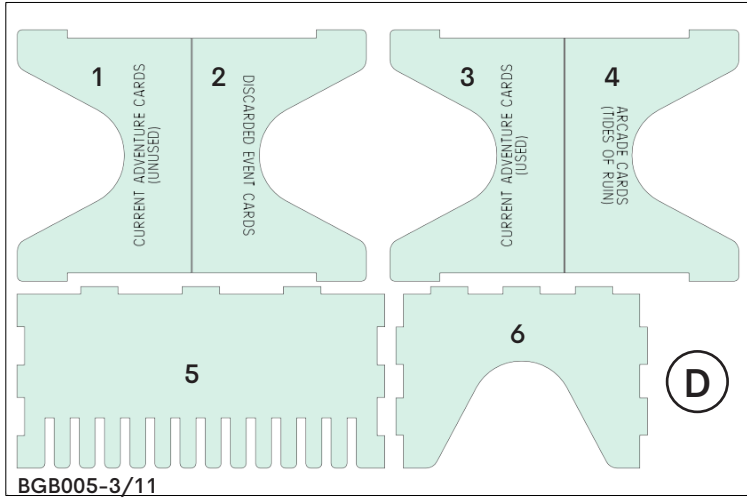
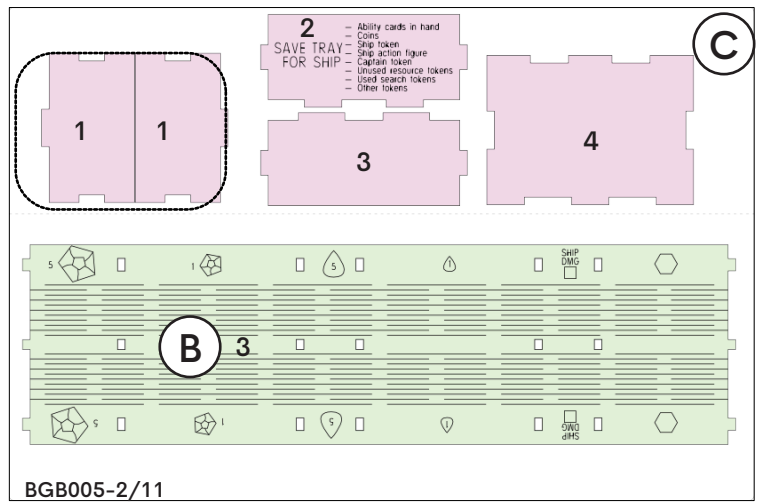
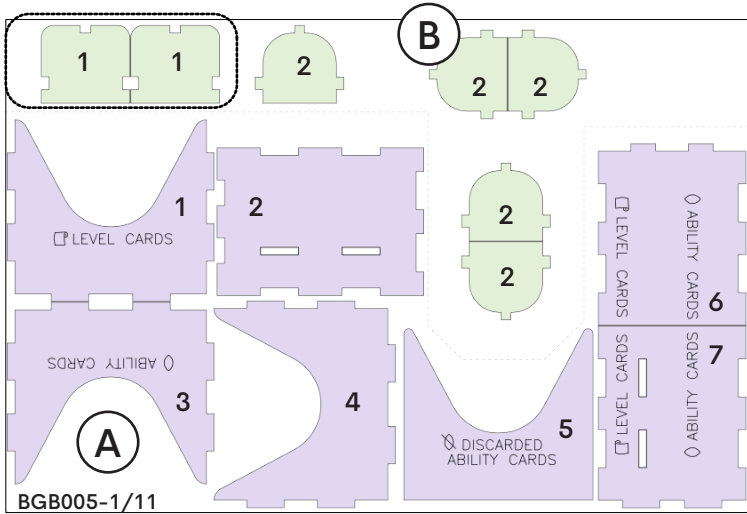

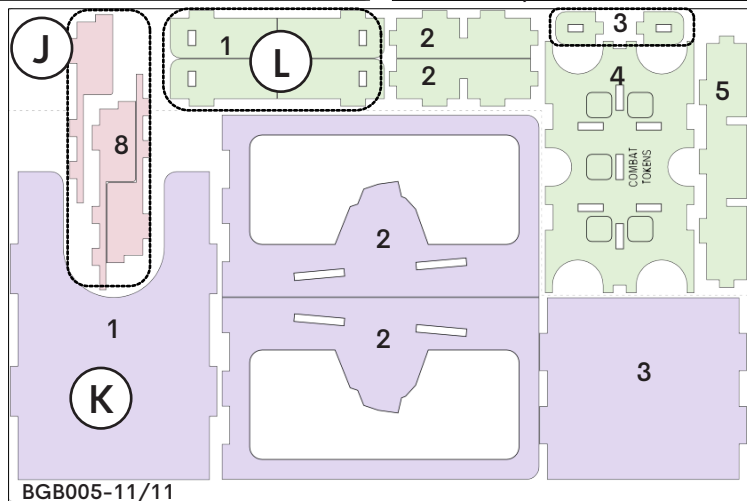
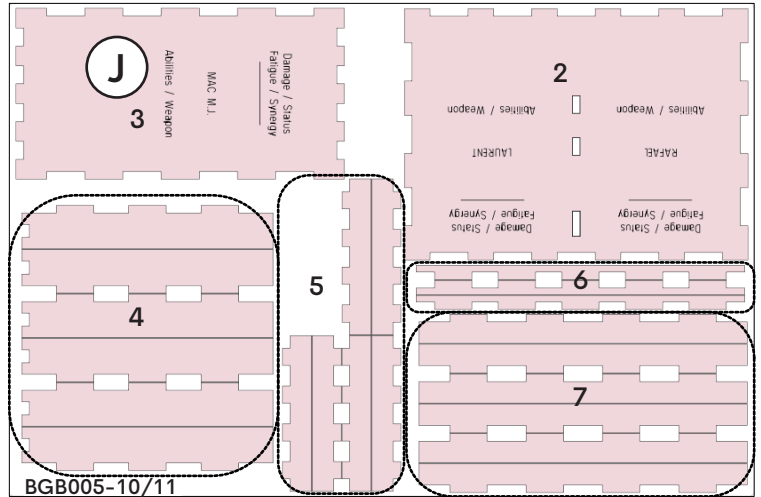
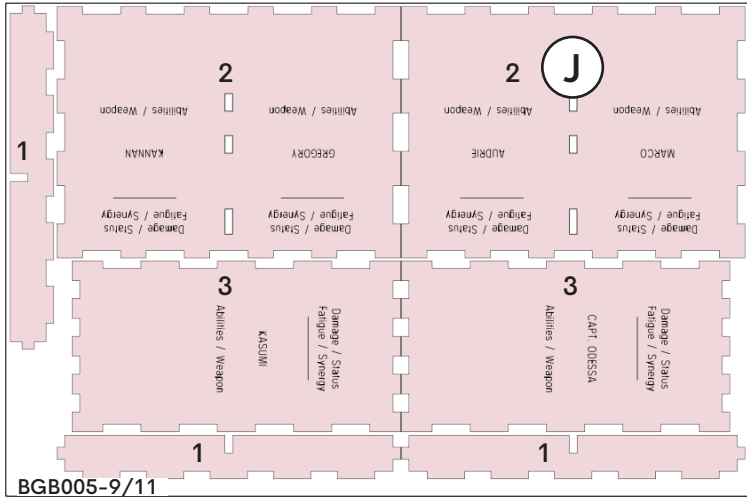
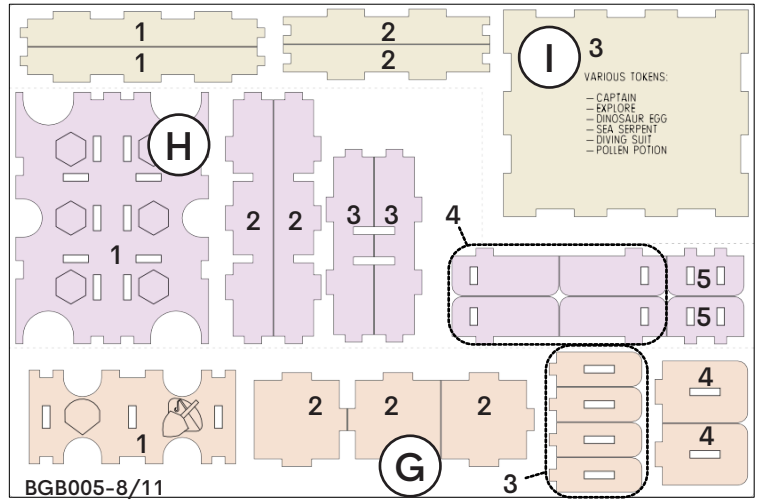
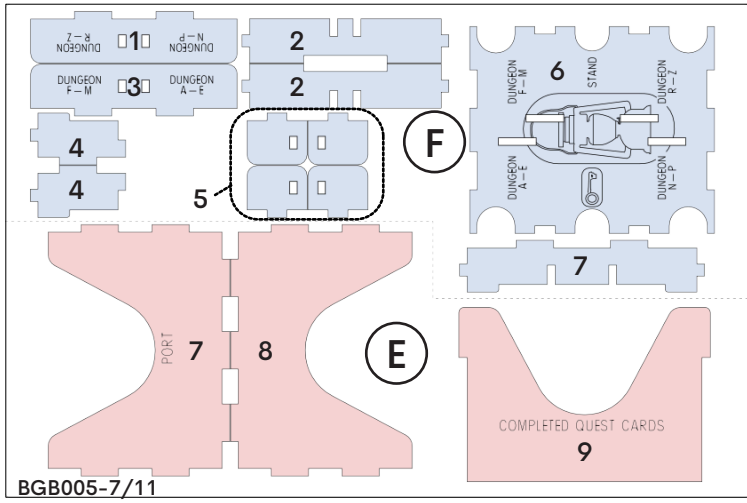

- VARIOUS TOKENS:**
- CAPTAIN
  - EXPLORE
  - DINOSAUR EGG
  - SEA SERPENT
  - DIVING SUIT
  - POLLEN POTION

(A) 1

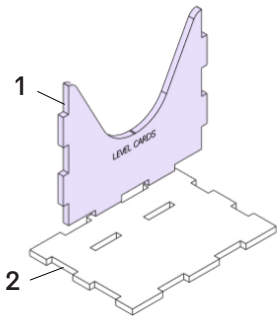

2

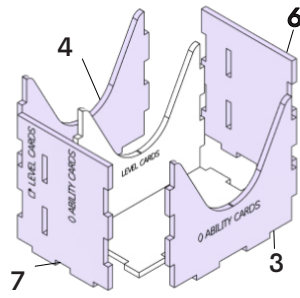

3

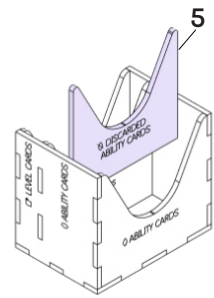

(A)



(B) 1

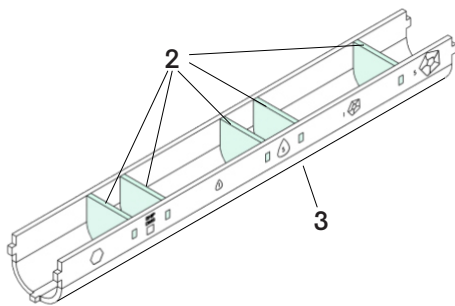

2

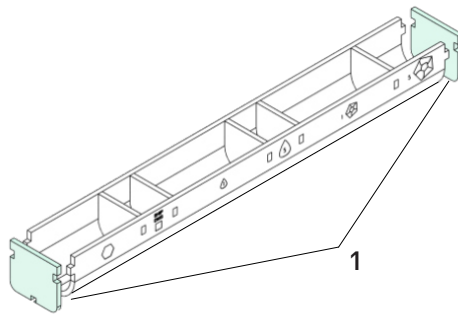

(C) 1

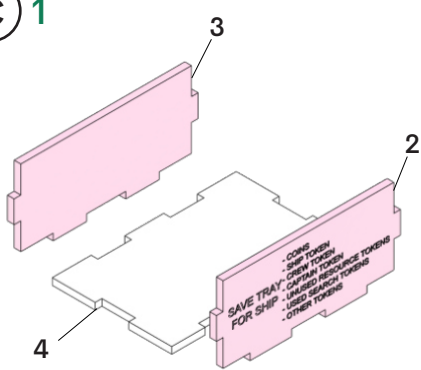

2

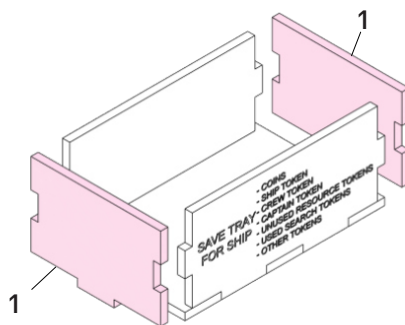

(D) 1

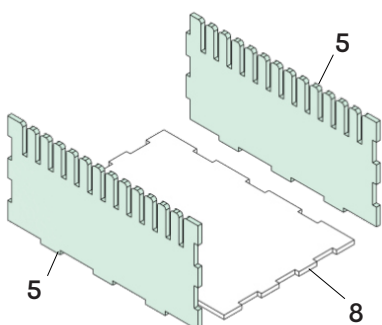

2

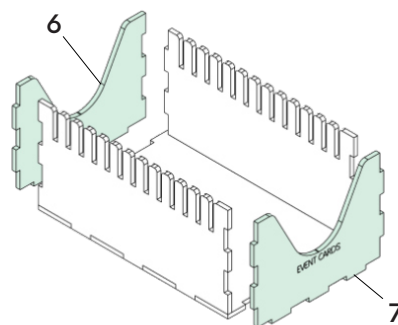

3

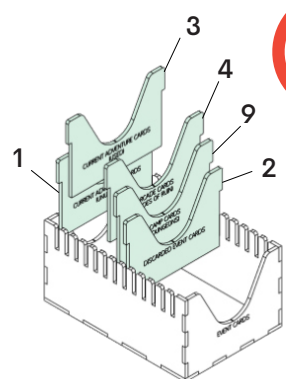

D



E 1

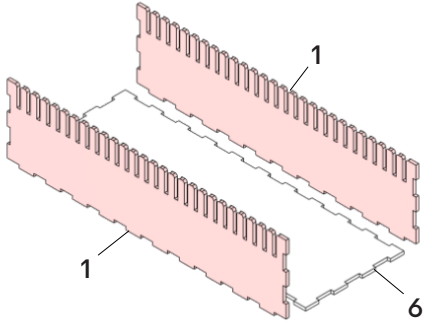

2

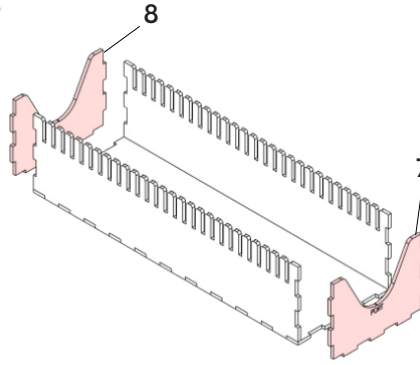

3

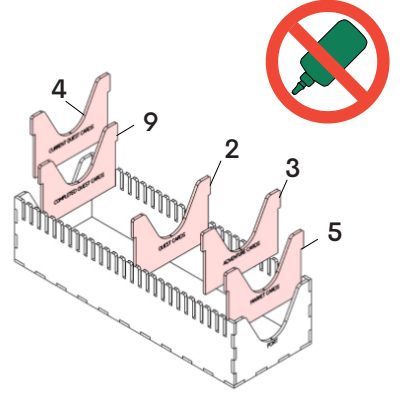

E

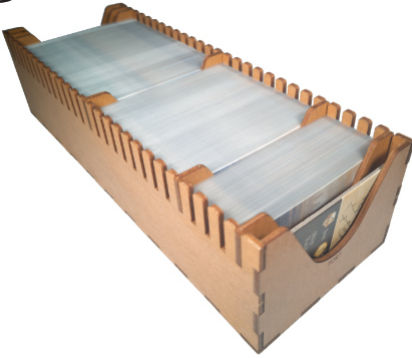

F 1

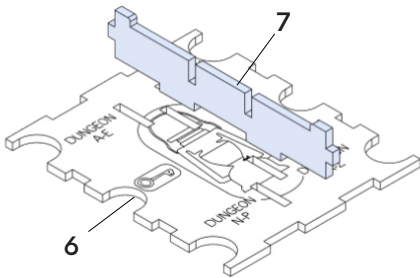

2

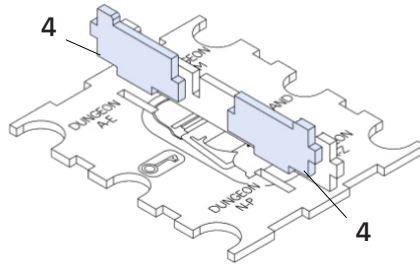

3

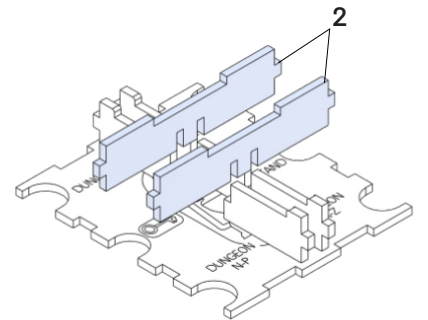

F 4

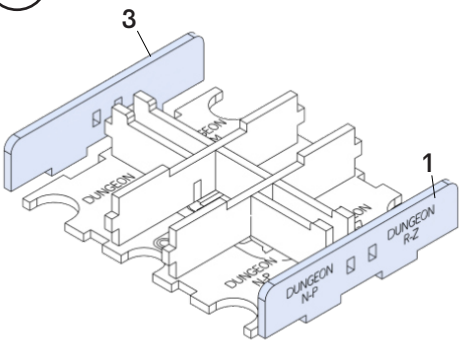

5

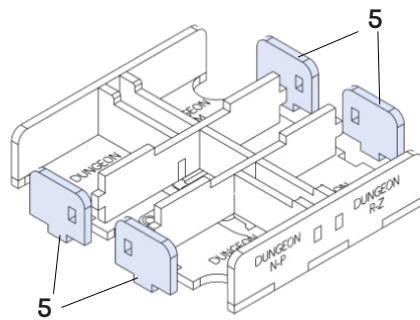

G 1

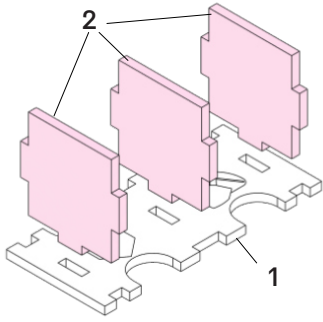

2

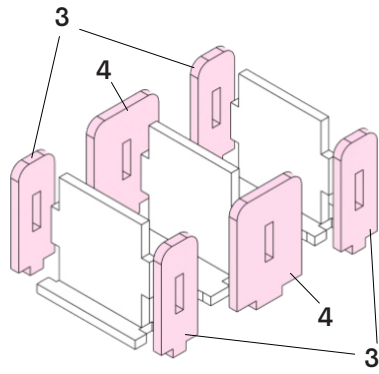

H 1

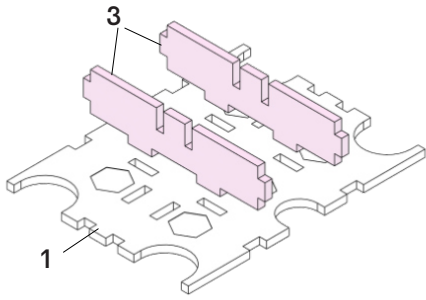

2

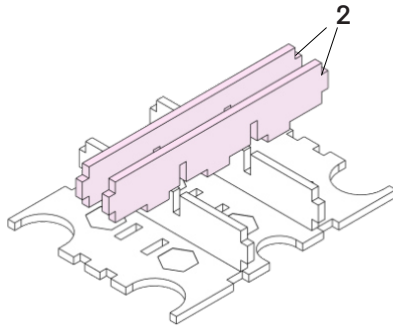

3

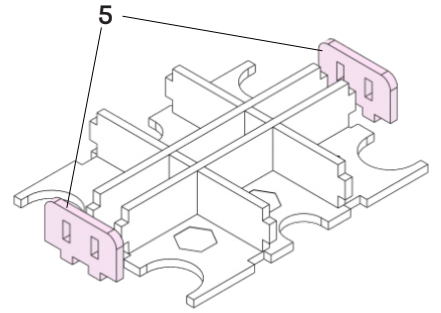

H 4

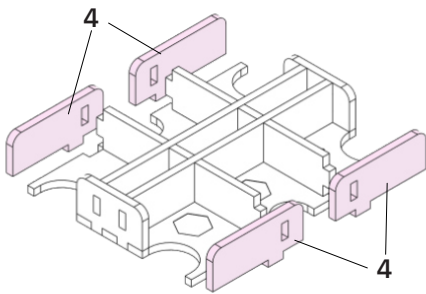

I 1

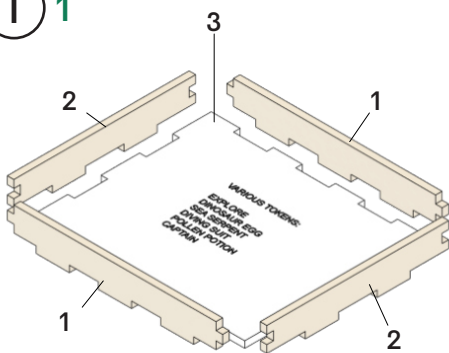

2



J 1

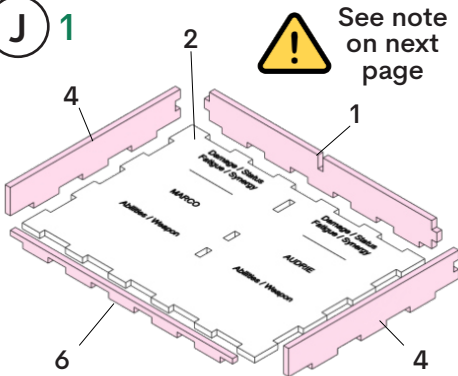

2

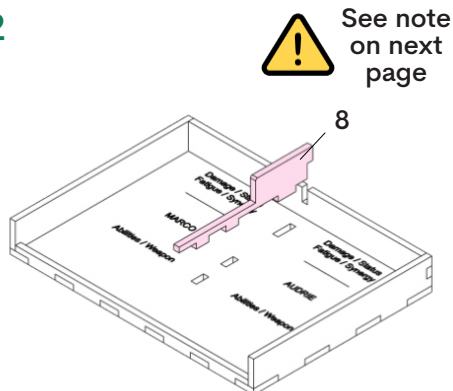

3

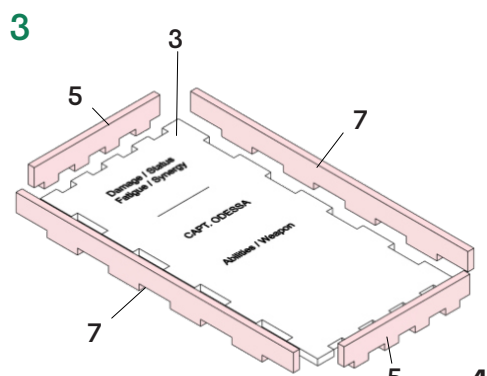

J

x3



Note: Parts J6 and J8 may break during assembly. Spares are provided.

K 1

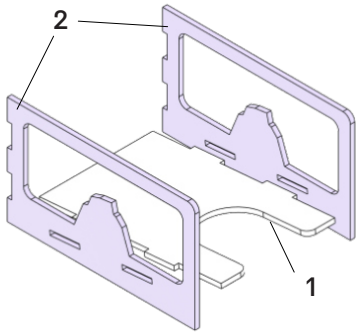

2

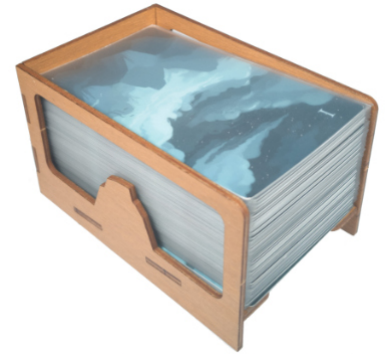
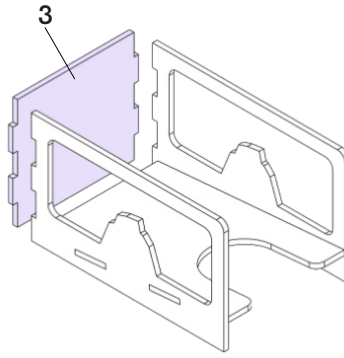

L 1

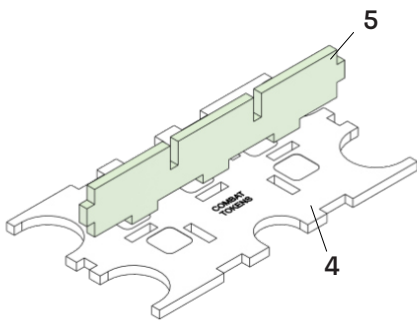

2

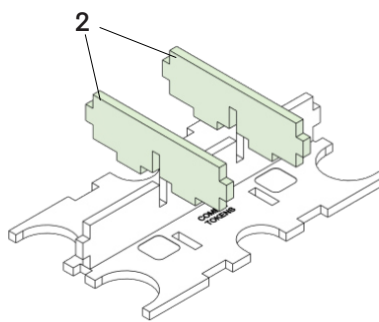

3

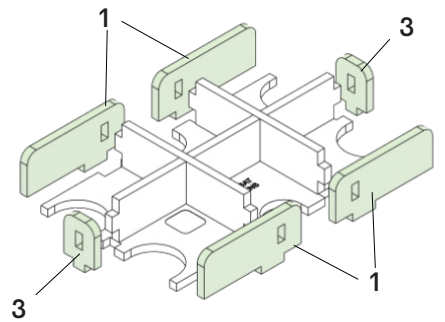

L



O